

SPECIFICATION

For

SWITCHING POWER SUPPLY

M/N: MPI-G505(-SB)(C/F)

Revision History

Version	Revise Date	Change Items
Rev. 01	Apr. 15. 2021	Established.
Rev. 02	Mar. 07. 2022	Changed 5VSB OVP 8.1V Max to 5VSB OVP 8.25V Max.
Rev. 03	May. 17. 2022	Changed Thermal Considerations.
Rev. 04	Dec. 27. 2022	1. Added note for safety" Applied to Class I stationary devices and system ground wires must meet the grounding test requirements". 2. Added "UKCA" logo.
Rev. 05	July. 27. 2023	Changed Derating Curve.
Rev. 06	Dec. 12. 2023	Changed Mechanical diagram and Safety.
Rev. 07	Feb. 26. 2024	Changed Safety.

MPI-G505(-SB)(C/F)

500W AC / DC



FEATURES

- ✓ 500W fan cooling, 300W with convection-cooled of single output power supply.
- ✓ Compact size 3 x 5 inch and low profile.
- ✓ High efficiency up to 95%.
- ✓ No-load power consumption < 0.5W.
- ✓ Optional +5Vsb and remote on/off function.
- ✓ ITE safety standard IEC 62368-1, BS IEC 62368-1, UL 62368-1, CSA C22.2 No. 62368-1 CE LVD approved.
- ✓ Design to meet EN 60335-1, IEC 60335-1, UL 60335-1, BS EN 60335-1.
- ✓ Meets EMI CISPR/FCC class B.
- ✓ PFC meet EN 61000-3-2 Class D and EN 61000-3-3.



Models & Ratings

Model Number	Wattage (Rated / Max)	Output Voltage		Min. Current	Rated Current	Max (Fan cooling)	Peak
MPI-G505	300 W / 500 W	+24V		0 A	12.5 A	20.83 A	23.3 A
MPI-G505-SB	300 W / 500 W	V1	+24 V	0 A	12.5 A	20.83 A	23.3 A
		V2	+5 V	0 A	0.5 A	2 A	-

Note : Peak power 560W Maximum 10s from start-up phase.

Model no. coding:

M P I - G 5 0 5 - X - Y

(1) (2) (1)

X=	Output set
blank	Single output
SB	Dual output (with +5Vsb & remote on/off function)

(2)

Y=	Cover Type
blank	No cover, open frame 127*76.2*39mm
C	With cover only 136*82*40mm
F	With cover and built-in fan 156*82*40mm

Input

Characteristic	Minimum	Typical	Maximum	Units	Notes & Conditions
Input Voltage	80	115 / 230	264	VAC	Continuous input range.
Input Voltage – Fault Condition		300		VAC	5 seconds max.
Input Frequency	47	50 / 60	63	Hz	AC input.
Input Current			6	A	Nominal AC Input Voltage (115VAC), Max load.
Inrush Current			30 / 60	A	Nominal AC Input Voltage (115VAC/230VAC), one cycle at 25°C cold start.
No-load power consumption			<0.5	W	Nominal AC Input Voltage (115VAC/230VAC). Only with model MPI-G505-SB.
Switching Frequency		66		KHZ	Frequency conversion
Input Protection	One non-user serviceable internally located AC input line fuse. Fuse : 8A / 300VAC * 1pcs				

Output

Characteristic	Minimum	Typical	Maximum	Units	Notes & Conditions
Output Voltage		+24 V		DC	
		+5Vsb			
Output Current		12.5 ^(V1)	20.83 ^(V1)	A	
		0.5	2 ^(V2)		
Efficiency		94	95	%	At input 230VAC, rated load, above 1hr. warm up.
Initial Set Accuracy		±1.0 ^(V1) ±2.5 ^(V2)		%	Initial setting accuracy is adjusted at input 115VAC and output at 60% rated load.
Minimum Load		0		A	
Start Up Delay		1		Sec	Time required for initial output voltage stabilization.
Hold Up Time		12	20	mS	Nominal AC Input Voltage, rated load.
Line Regulation		±1.0 ^(V1) ±1.0 ^(V2)		%	Less than ±1% at rated load with ±10% changing in input voltage 115VAC.
Load Regulation		±1.0 ^(V1) ±1.0 ^(V2)		%	Measured from 60% to 100% rated load and from 60% to 20% rated load (60% ±40% rated load).
Ripple & Noise		240 ^(V1) 50 ^(V2)	360 ^(V1) 100 ^(V2)	mV	Measured at rated load by a 20MHz bandwidth limited oscilloscope and the each output is connected with a 10µF Electrolytic Capacitor and a 0.1µF Ceramic Capacitor.
Earth leakage Current			0.75	mA	At input 264VAC, 63Hz, rated load.
Power Good Signal	100		500	mS	When power is turned on, the power good signal will go high after the output voltage are within regulation limit.
Power Fail Signal	1			mS	When Unexpected power outage, the power fail signal will go low before the output voltage fall below the regulation limit.
Overvoltage Protection	For some reason the power supply fails to control itself, the build-in over voltage protection circuit will latch off the outputs to prevent damaging external circuits, the trigger point is around 110%~135% of output voltage. (Note1)				
Short Circuit Protection	Fully protected against output overload and short circuit. Automatic recovery upon of overload condition.				
Remote On / Off (optional)	The power supply will be turned on when the power On/Off pin is connected to secondary GND. This function exists only with optional +5Vsb.				

Note:

1. 5VSB OVP 8.25V Max & Auto recovery mode.

Environmental

Characteristic	Minimum	Typical	Maximum	Units	Notes & Conditions
Operating Temperature	-20		+80	°C	See the following performance curves for the detail.
Storage Temperature	-40		+85	°C	
Relative Humidity	5		95	%RH	Non-condensing.
Cooling		16.8		CFM	With cover forced-cooled when 301W~500W.
Operating		5000		m	

Derating curve

1. Output Power (W) versus Ambient Temp.(°C) Curve

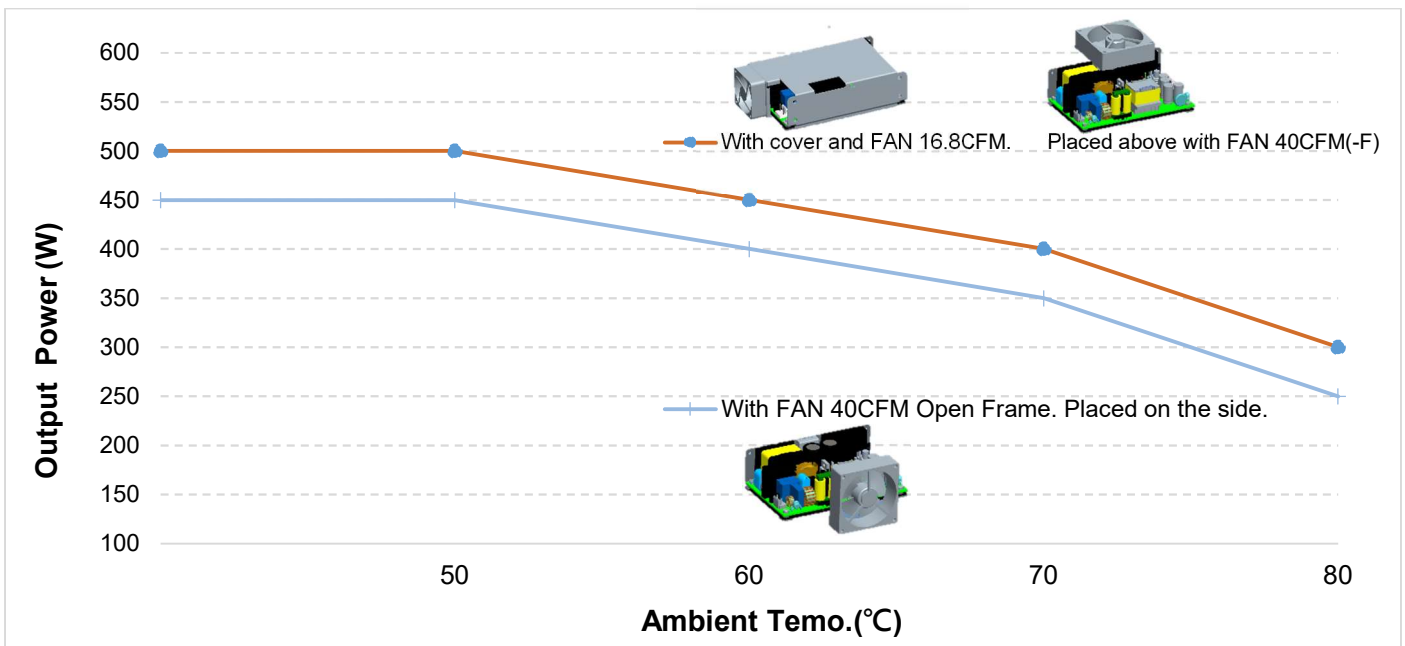
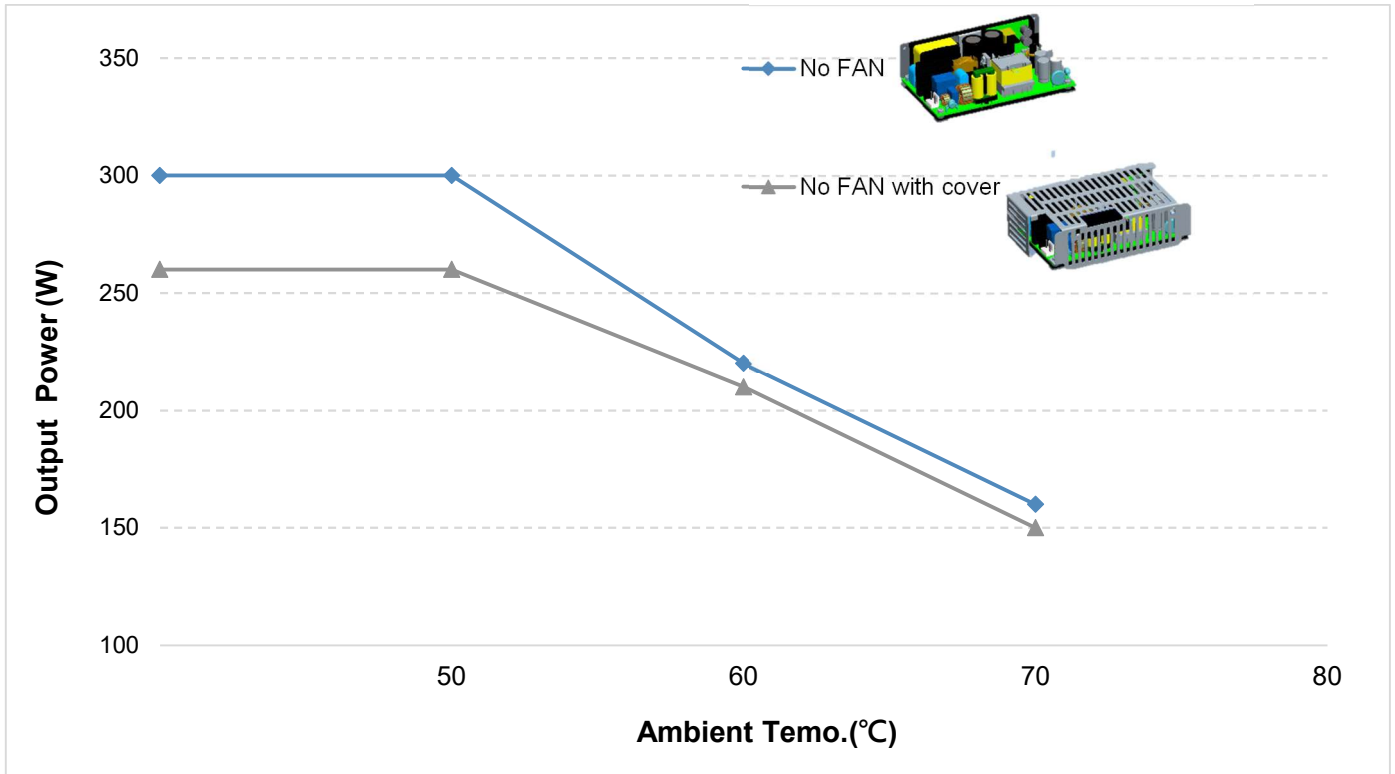

2. Output Power (W) versus Input Voltage(VAC) Curve

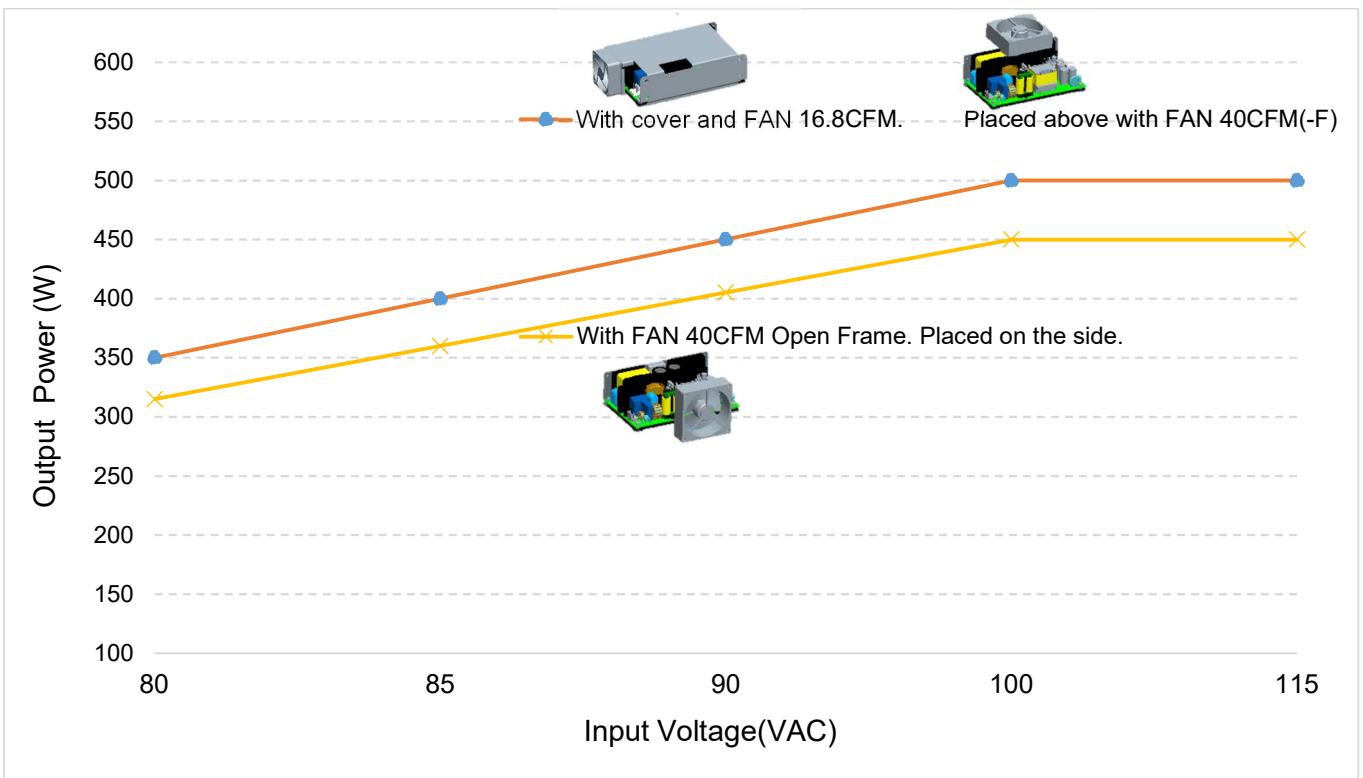
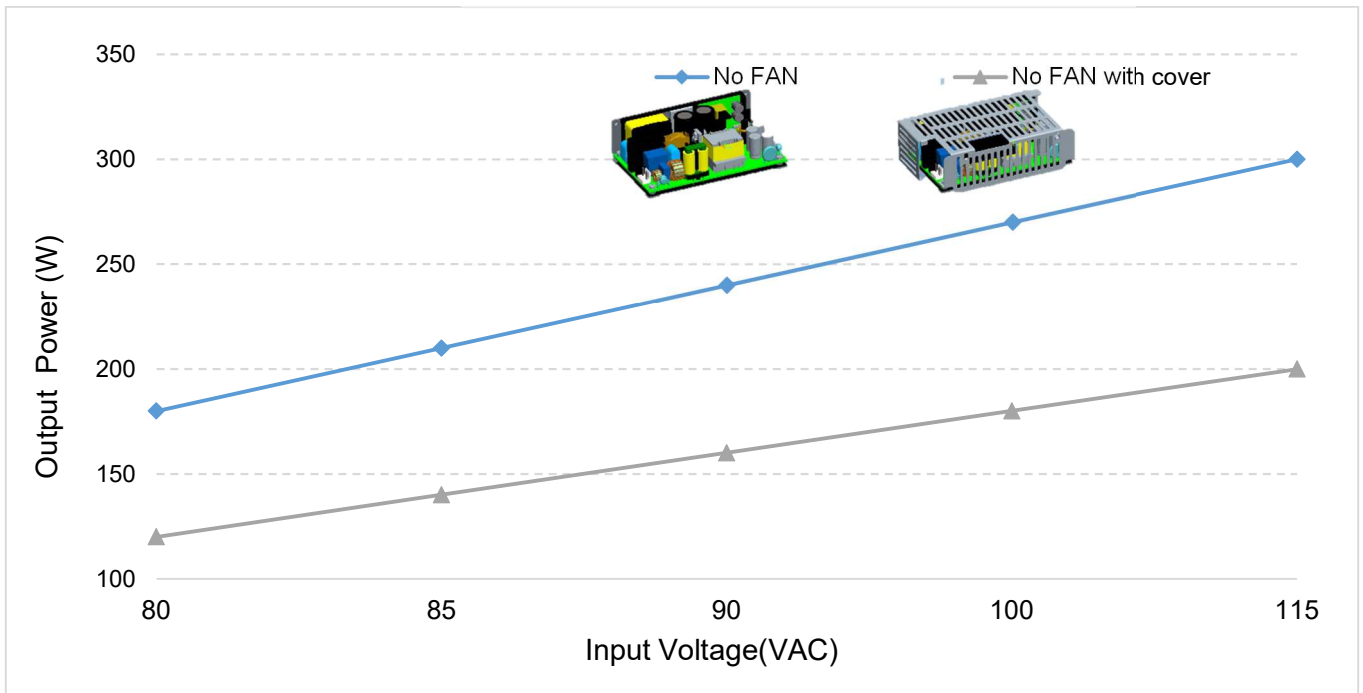

Note: If the operating temp exceeds 50°C, please refer to graph 1 for deration curve and according output proportion.

3. 5VSB: Output Current (A) versus Ambient Temp.(°C) Curve

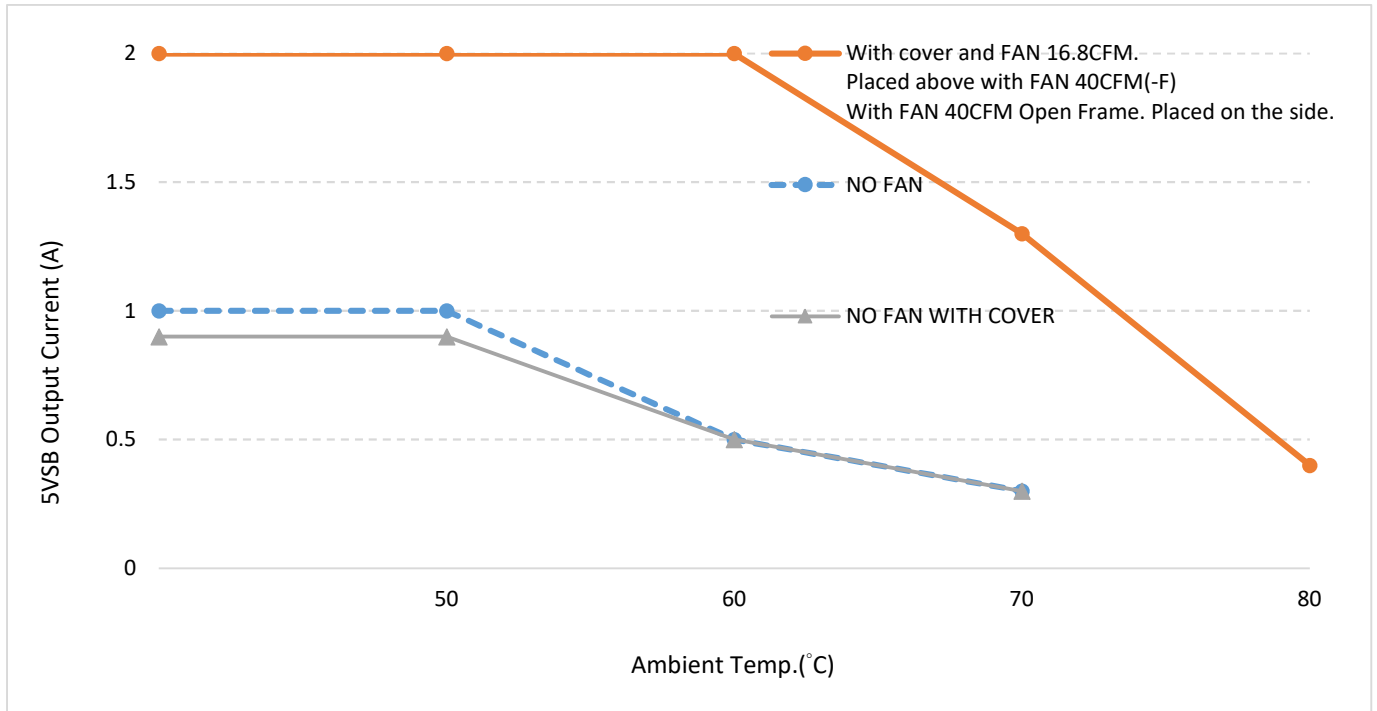

4. Peak Power (W) versus Input Voltage(VAC) Curve

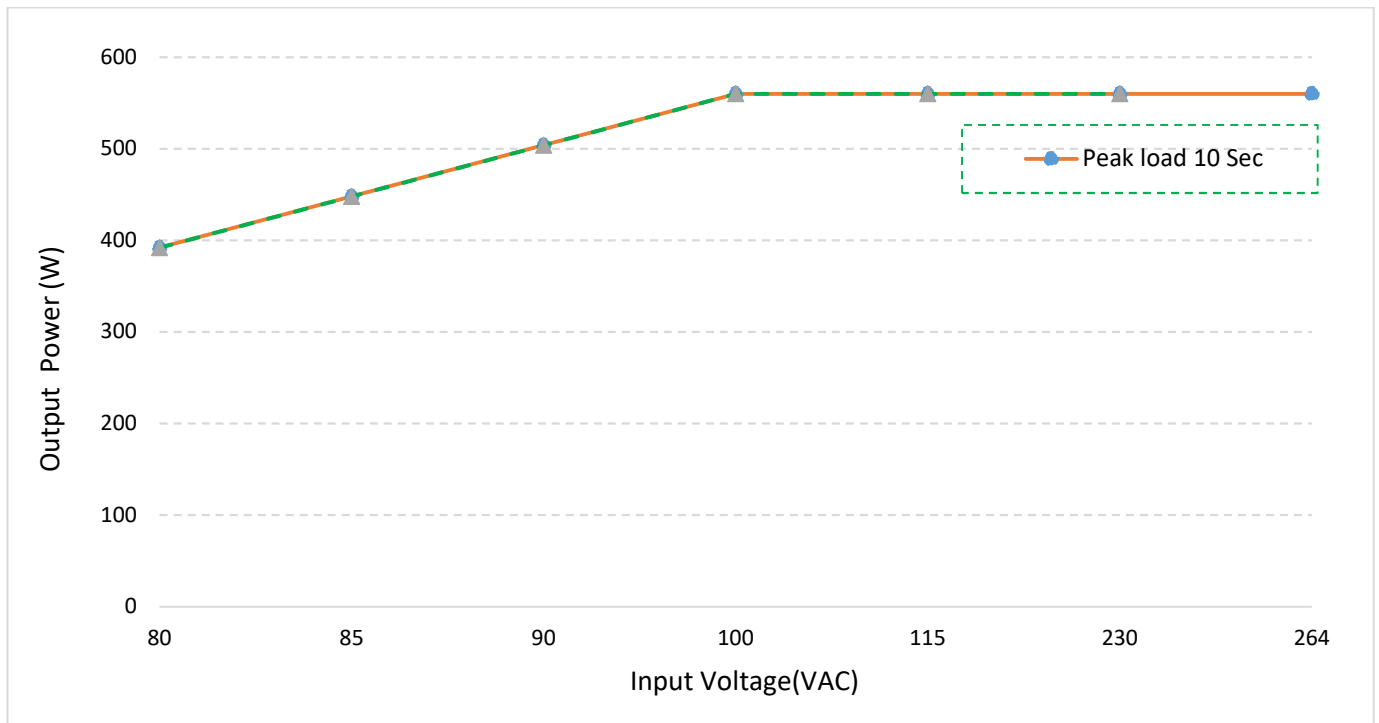

EMC: Emissions

Phenomenon	Standard	Class	Notes & Conditions
Conducted	EN 55022 / EN 55032 CISPR 22 & FCC Part 15 BS EN 55022 / BS EN 55032:2015+A11:2020 CISPR 22 & FCC Part 15	B	
Radiated	EN 55022 / EN 55032 CISPR 22 & FCC Part 15 BS EN 55022 / BS EN 55032:2015+A11:2020 CISPR 22 & FCC Part 15	B	
Harmonic Current	EN 61000-3-2 BS EN 61000-3-2:2019	D	Rated load
Voltage Flicker	EN 61000-3-3 BS EN 61000-3-3:2013+A1:2019	PASS	

EMC: Immunity

Phenomenon	Standard	Criteria	Notes & Conditions
ESD	IEC 61000-4-2 BS IEC 61000-4-2	A	±8KV air discharge, ±6KV contact discharge
Radiated	IEC 61000-4-3 BS IEC 61000-4-3	A	10V/m
EFT	IEC 61000-4-4 BS IEC 61000-4-4	A	±2KV Line & PE
Surges	IEC 61000-4-5 BS IEC 61000-4-5	A	L-N:±1KV, L/N-PE:±2KV
Conducted	IEC 61000-4-6 BS IEC 61000-4-6	A	10V
Power Magnetic	IEC 61000-4-8 BS IEC 61000-4-8	A	10A/m
Dips and Interruptions	IEC 61000-4-11 BS IEC 61000-4-11	A A / B A / B B	DIP: >95%, 0.5 cycle DIP: 30%, 25 cycles (Note 2 & Note4) DIP: 60%, 5 cycles (Note 2 & Note4) INT: >95%, 250 cycles

Note:

- As a build-in type power supply, the power supply needs to be installed in a suitable enclosure to pass the EMI/EMC tests. The final assembly has to comply with the valid EMI/EMC and safety.
- The dips test result of input 240Vac / 100Vac is criteria A / B.
- The mounting holes should be connected to each other to conform the EMI limit.
- The dips test result of output 300W / 500W is criteria A / B.

Safety Approvals

Characteristic	Minimum	Typical	Maximum	Units	Notes & Conditions
Isolation	IP to OP	3000		VAC	Isolation
	IP to GND	1800		VAC	
Safety Agency	Safety Standard				Notes & Conditions
CE(LVD), UKCA	BS EN 62368-1, 2 nd ,3 rd Edition, EN 62368-1 2 nd ,3 rd Edition				Approved.
UL/cUL	UL 62368-1, 3 rd Edition, CAN / CSA C22.2 No. 62368-1:19, 3 rd Edition				Approved.
CE, UKCA	EN 60335-1, IEC 60335-1, UL 60335-1, BS EN 60335-1				Designed to meet ^(Note 1) .
CB	IEC 62368-1, 3 rd Edition				Approved.

Note:

- Applied to Class I stationary devices and system ground wires must meet the grounding test requirement

Mechanical Details

All dimensions are in Inches [mm] Tolerance ± 0.02 [± 0.5]

MPI-G505(-SB)

Ac Input Connector CN1	
1.MOLEX molex 09-65-2038 OR Equivalent	
2.JST B2P3- VH-B(LF)(SN) OR Equivalent	
note:remove the middle pin	
PIN number	PIN assignment
1	AC in(L)
2	AC in(N)

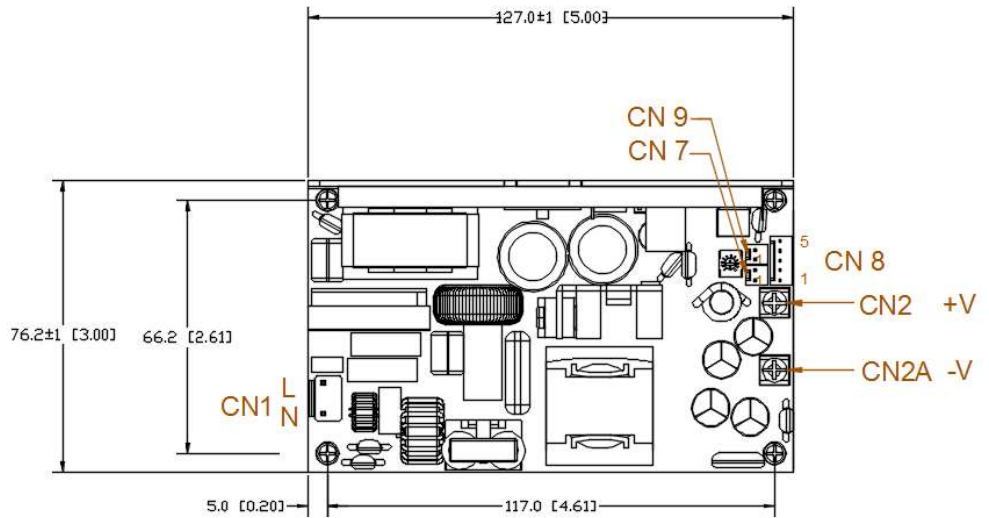

Remote Sense CN7	
MOLEX6410-02A or Equivalent	
PIN number	PIN assignment
1	+Sen
2	-Sen

Singal Connector CN9	
MOLEX6410-02A or Equivalent	
PIN number	PIN assignment
1	12V Fan 0.48A Max
2	0V

Singal Connector CN8	
MOLEX6410-05A or Equivalent	
PIN number	PIN assignment
1	Fan 12V (V _{Fan})
2	0V
3	+5VSB(V ₂)
4	PG/PF
5	Remote

Dc Output Terminal Blocks	
CN2 / CN2A	
DINKLE P-820W	
European type by request	
PIN number	PIN assignment
CN2	+V
CN2A	-V

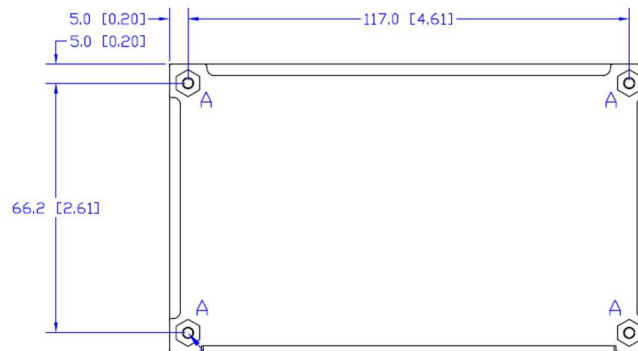
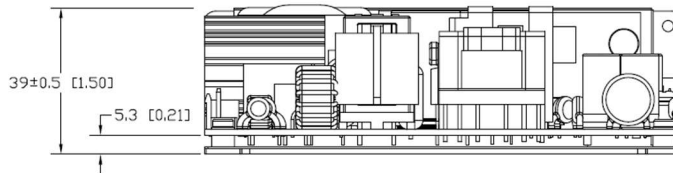

M3 mounting hole (in 4 positions)
3.0mm max screw penetration(A)

MPI-G505-C

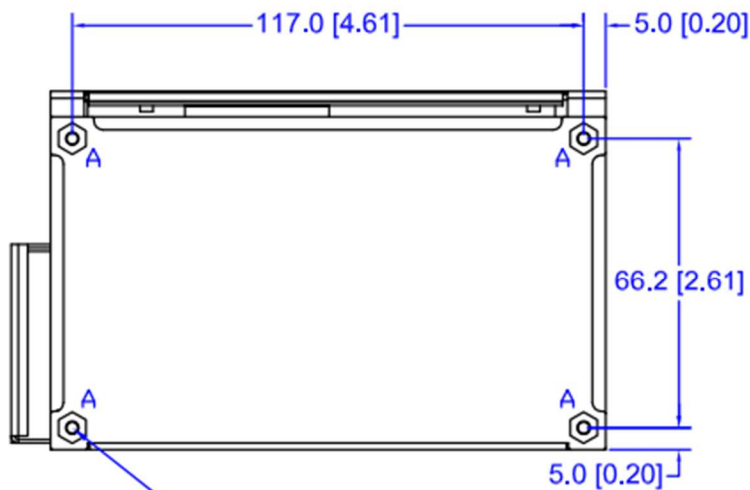
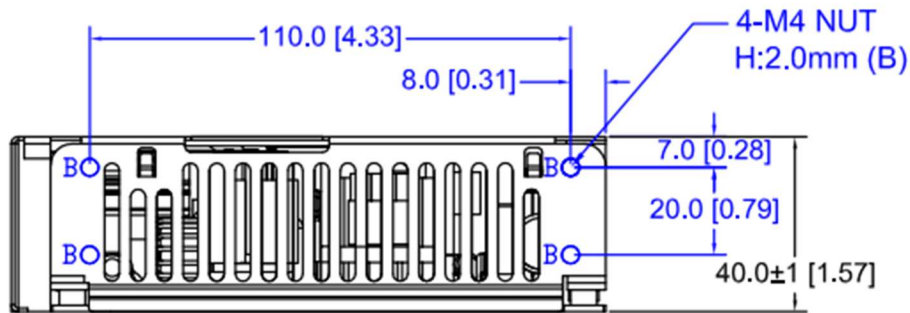
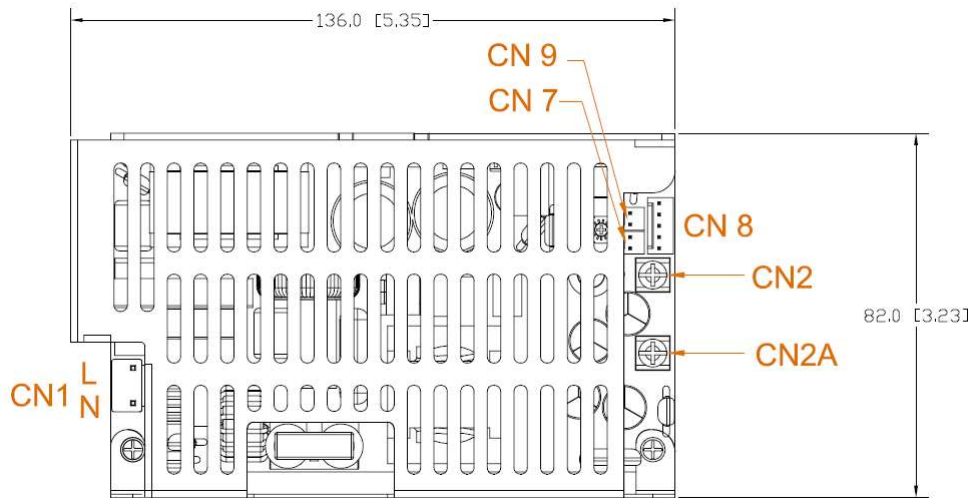

M3 mounting hole (in 4 positions)
3.0mm max screw penetration(A)

MPI-G505-F

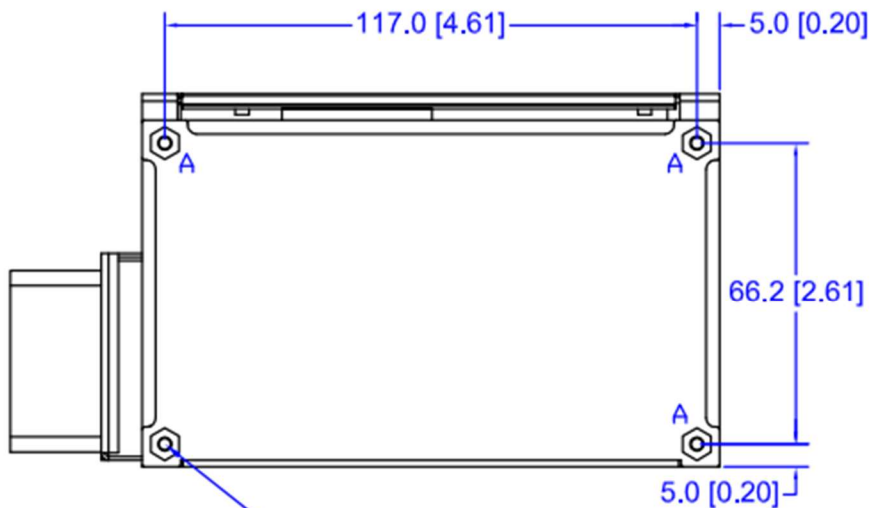
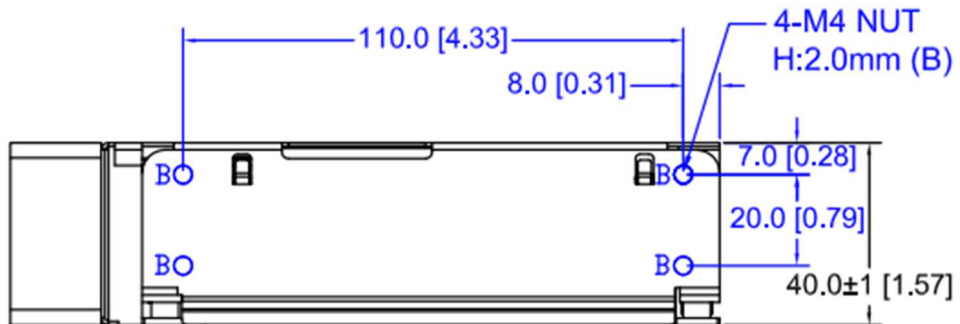
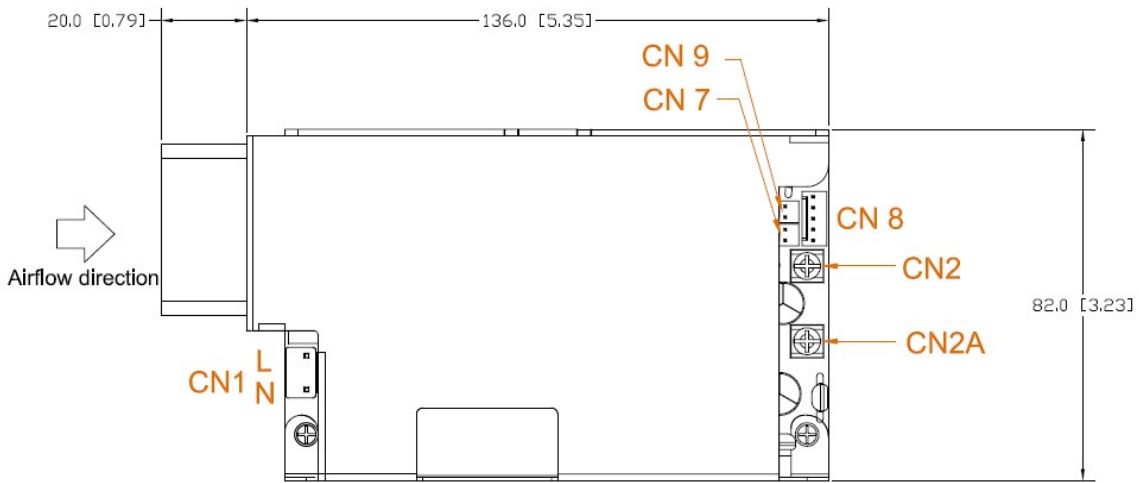

M3 mounting hole (in 4 positions)
3.0mm max screw penetration(A)

Fan placed above.



50° C 500W

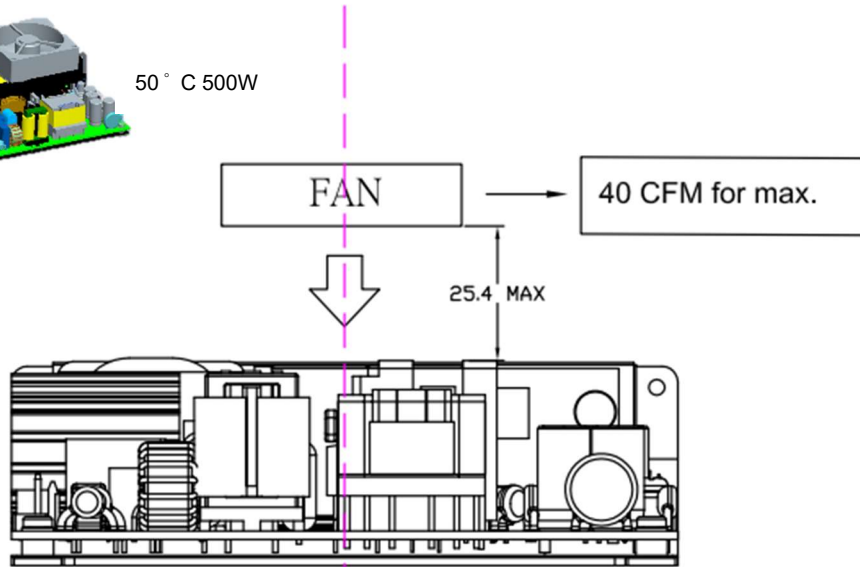

Fan placed on the side.

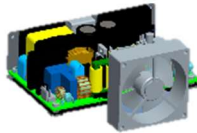

50° C 450W

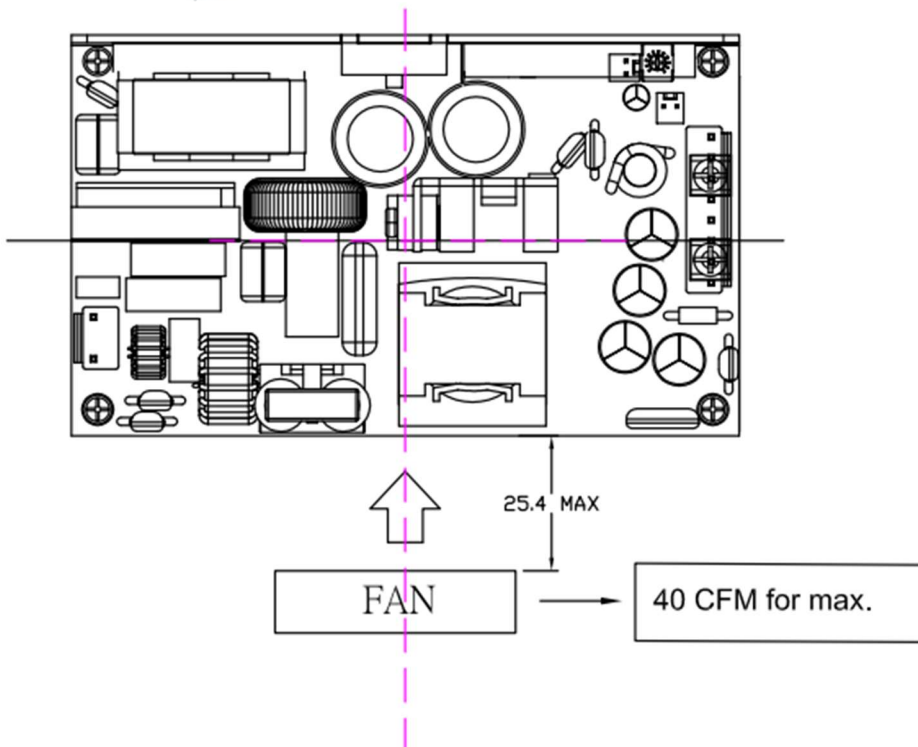

Thermal Considerations

In order to ensure safe operation of the PSU in the end-use equipment, the temperature of the components listed in the table below must not be exceeded. Temperature should be monitored using J type thermocouples placed on the hottest part of the component (out of any direct air flow). See Mechanical Details for component locations.

Temperature Measurements at max. amb.	
Component	Max Temperature
T1	110°C
Q2	130°C
D1	130°C
C33	105°C
C4, C5	105°C

Performance

(Input voltage: 115Vac)

Switching frequency ripple rated load

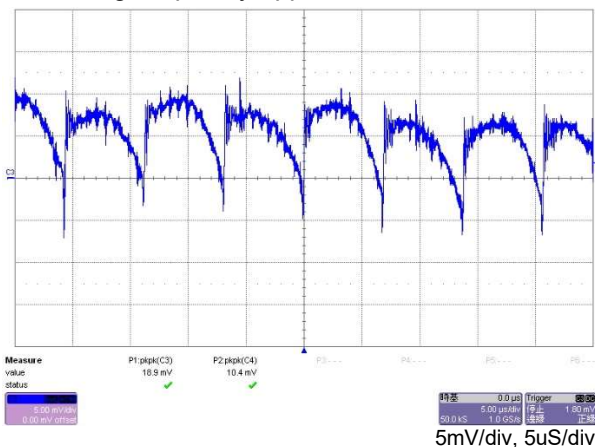

Line frequency ripple rated load

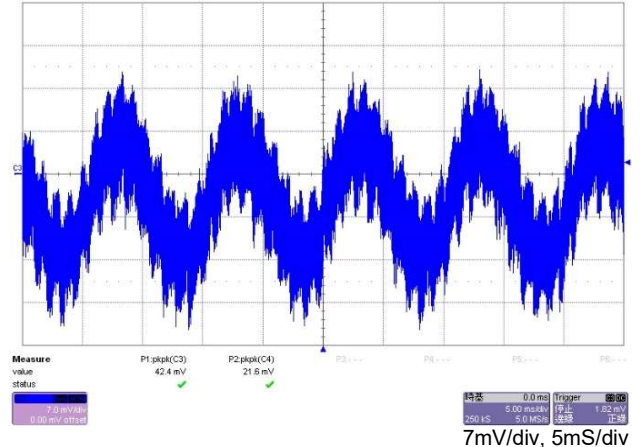

Output turn-on rated load



Output turn-off rated load

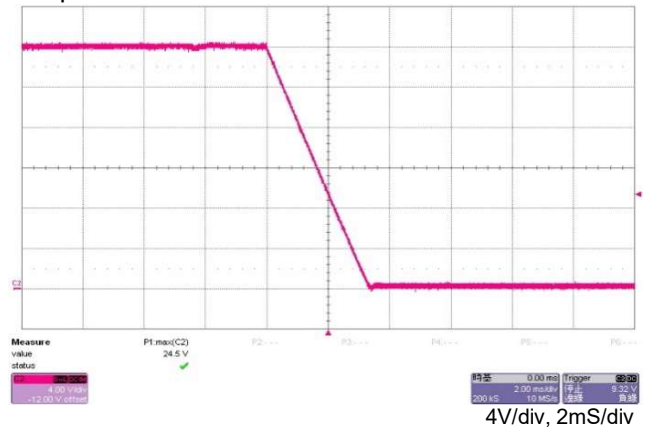

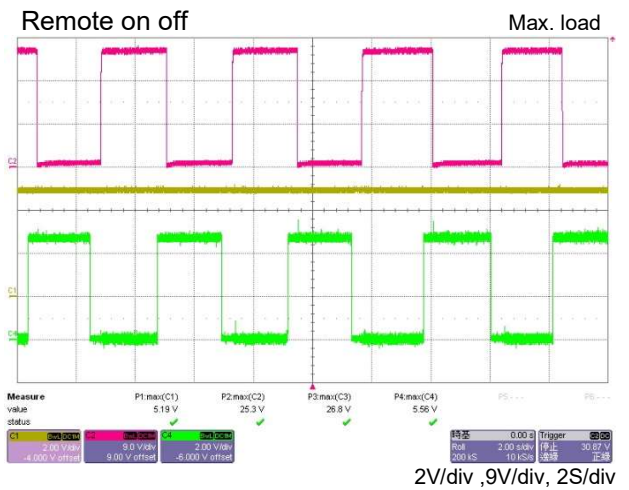
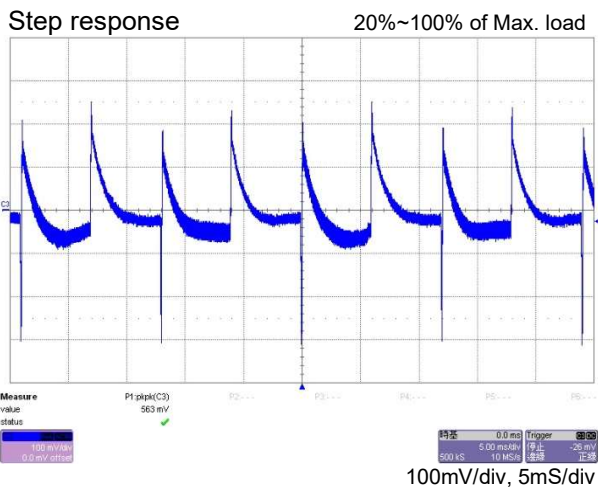
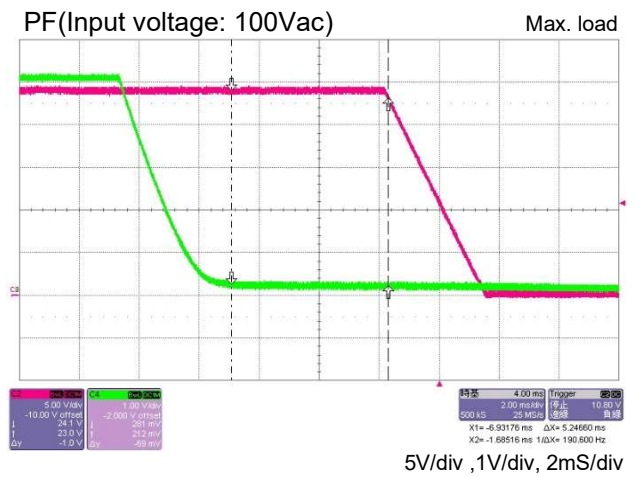
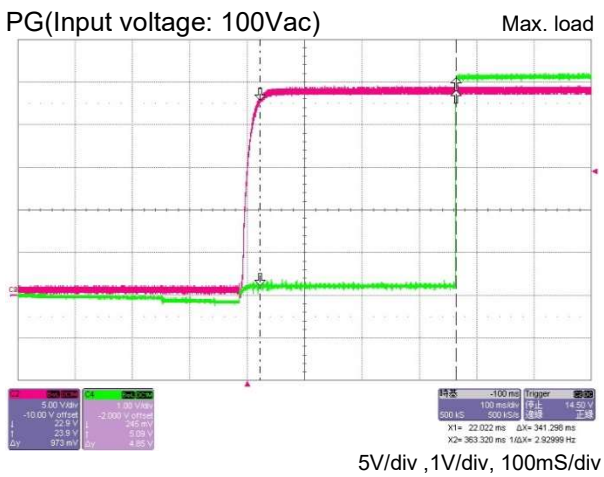
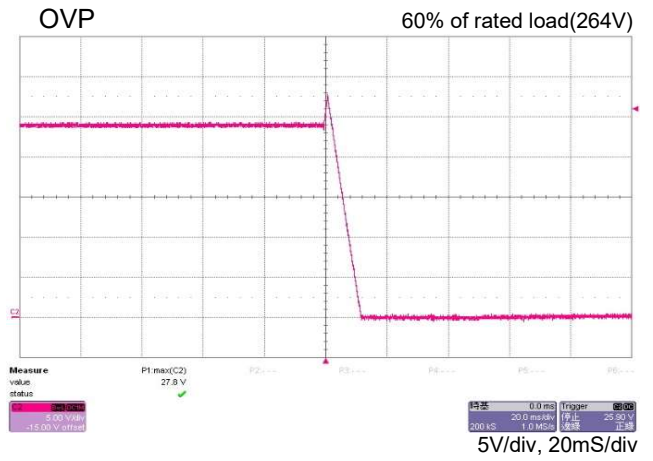
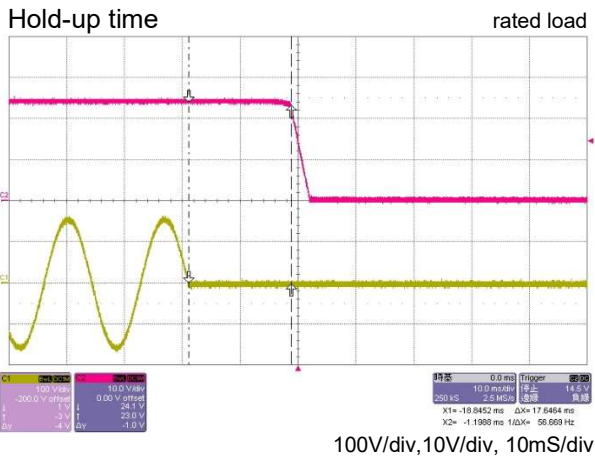

EMI: EN55011 "B" (Conduction)

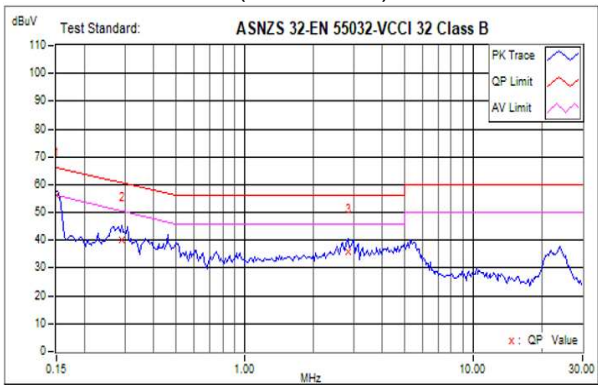

230Vac/rated load

EMI: FCC "B" (Conduction)



115Vac/rated load

EMI: EN55011 "B" (Radiation)

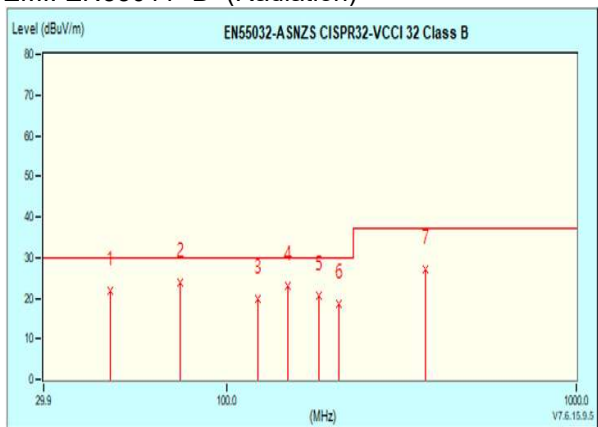

230Vac/rated load

EMI: FCC "B" (Radiation)

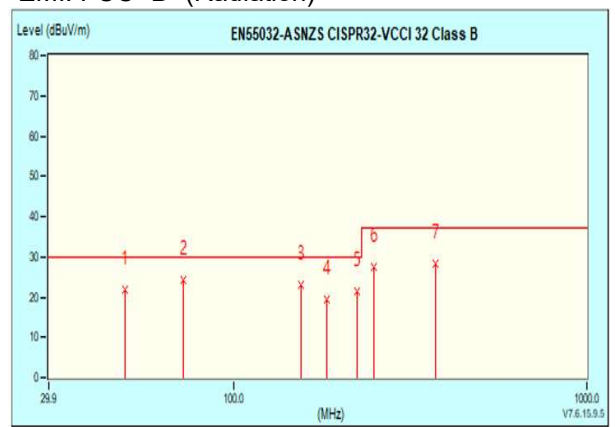

115Vac/rated load

User manual

1. The product covered is a Built-in power supply intended for used with audio/video, information and communication technology equipment.
2. The open frame type SPS shall be operated according the following specification.
3. The open frame type SPS can be operated at an ambient temperature **50°C**.
4. The open frame type SPS shall be operated in dry locations to protect from moisture.
5. Transportation & Storage temperature/humidity: $-20^{\circ}\text{C} \sim +85^{\circ}\text{C} / 0\% \sim 93\%$.
6. Operation temperature/humidity: $-20^{\circ}\text{C} \sim +50^{\circ}\text{C} / 0\% \sim 95\%$.
7. The leakage current test was performed for information only and has to be verified in the end use application. Open frame switching power supply was evaluated as reinforced insulation between primary and secondary.
8. Repair / maintenance:

Please do not try to fix the power supply by yourself! Please contact us for detailed information.
9. A suitable fire and electrical enclosure may be required or provided by the system.
10. The load on output shall not exceed the label Input Rating: 100-240 V \sim 7-3 A 47-63 Hz
11. **"WARNING"**: No modification of this equipment is allowed.
"WARNING": To avoid risk of electric shock, this equipment must only be connected to a supply main with protective earth.
12. Follow the national requirement to dispose unit.
13. An investigation of the protective bonding terminals has: Fan Chassis and Bottom metal Chassis shall be secured bonded to protective bonding terminal in the end-use product.
14. Condition of Fan type: External Fan, air flow: 40 C.F.M. blow into the unit, see below for details:

